

MATLAB Based Simulation of TCSC FACTS Controller

Preeti Singh, Mrs.Lini Mathew, Prof. S. Chatterji
N.I.T.T.R., Chandigarh.

Abstract-Power system engineers are currently facing challenges to increase the power transfer capabilities of existing transmission system. This is where the Flexible AC Transmission Systems (FACTS) technology comes into effect. With relatively low investment, compared to new transmission or generation facilities, the FACTS technology allows the industries to better utilize the existing transmission and generation reserves, while enhancing the power system performance. Moreover, the current trend of deregulated electricity market also favors the FACTS controllers in many ways. FACTS controllers in the deregulated electricity market allow the system to be used in more flexible way with increase in various stability margins. FACTS controllers are products of FACTS technology; a group of power electronics controllers expected to revolutionize the power transmission and distribution system in many ways. The FACTS controllers clearly enhance power system performance, improve quality of supply and also provide an optimal utilization of the existing resources. Thyristor Controlled Series Compensator (TCSC) is a key FACTS controller and is widely recognized as an effective and economical means to enhance power system stability. In this paper an overview to the general types of FACTS controllers is given along with the simulation of TCSC FACTS controller using SIMULINK. Analysis of the simulated TCSC shows similar functions as a physical one. The simulated TCSC shows that the oscillations are damped out on increasing the damping coefficient. Change in value of reactance of the TCSC also affects the stability of the system.

KEYWORDS: FACTS, Power system, Stability, Transient stability, Transient stability limit, Voltage stability, Thermal rating, Power system flexibility, Synchronism.

I. INTRODUCTION

Modern electric power utilities are facing many challenges due to ever-increasing complexity in their operation and structure. In the recent past, one of the problems that got wide attention is the power system instabilities. With the lack of new generation and transmission facilities and over exploitation of the existing facilities geared by increase in load demand make these types of problems more imminent in modern power systems.

Demand of electrical power is continuously rising at a very high rate due to rapid industrial development. To meet this demand, it is essential to raise the transmitted power along with the existing transmission facilities. The need for the power flow control in electrical power systems is thus evident. With the increased loading of transmission lines, the problem of transient stability after a major fault can become a transmission power limiting factor. The power system should adapt to momentary system conditions, in other words, power system should be flexible. The idea of the so-called Flexible

AC Transmission System (FACTS) has been introduced in 1980s.

II. POWER SYSTEM STABILITY

Power system stability may be broadly defined as the ability of a power system to remain in a state of operating equilibrium under normal operating conditions and to regain an acceptable state of equilibrium after being subjected to a disturbance. Traditionally, the stability problem has been one of maintaining all synchronous machines in synchronism. This aspect of stability is influenced by the dynamics of generator rotor angles.

Stability of power system has been a major concern in system operation. The stability of a system determines whether the system can settle down to the original or close to the steady state after the transients disappear. In general, power system stability is the ability to respond to a disturbance from its normal operation by returning to a condition where the operation is again normal.

A power system is said to be steady state stable for a particular operating condition if, following any small disturbance, it reaches a steady state operating condition which is identical or close to the pre-disturbance operating condition.

Transient stability is defined as the ability of the power system to maintain synchronism when subjected to a severe transient disturbance. A system is transiently stable if it can survive the initial disturbance but it is transiently unstable if it cannot survive. For the transiently stable system, a large disturbance suddenly occurs, the system angle spread starts to increase but reaches a peak and then starts to decline, making the system transiently stable. The resulting system response involves large excursions of generator rotor angles. Transient stability is sometimes called first swing stability as the instability often occurs during the first angle swing.

III. TRANSIENT STABILITY IMPROVEMENT BY FACTS

By the means of flexible and rapid control over the AC transmission parameters and network topology, FACTS technology can facilitate the power control, enhance the power transfer capacity, decrease the line losses and generation costs, and improve the stability and security of the power system. According to IEEE, FACTS Controller is "A power electronic based system and other static equipment that provide control of one or more ac transmission system parameters."

FACTS technology opens up new opportunities for controlling and enhancing the useable capacity of present, as well as new upgraded lines. FACTS is an evolving technology

and can boost power transfer capability by 20–30% by increasing the flexibility of the systems.

By providing added flexibility, FACTS controllers can enable a line to carry power closer to its thermal rating. FACTS device offers continuous control of power flow or voltage, against daily load changes or change in network topologies.

IV. TYPES OF FACTS CONTROLLERS

In general FACTS controllers can be divided into the following four categories:

A. SERIES CONTROLLERS

In principle all the series controllers inject voltage in series with the line. Series connected controller impacts the driving voltage and hence, the current and power flow directly. Static Synchronous Series Compensator (SSSC), Thyristor Controlled Series Compensator (TCSC) etc. are the examples of series controllers.

B. SHUNT CONTROLLERS

All shunt controllers inject current into the system at the point of connection. The shunt controller is like a current source, which draws/injects current from/into the line. Static Synchronous Compensator (SSC), Static Synchronous Generator (SSG), Thyristor Controlled Reactor (TCR) etc are the examples of shunt controllers.

C. COMBINED SERIES-SHUNT CONTROLLERS

This could be a combination of separate shunt and series controllers, which are controlled in a coordinated manner. Combined shunt and series controllers inject current into the system with the shunt part of the controller and voltage in series in the line with the series part of the controller. Unified Power Flow Controller (UPFC) and Thyristor Controlled Phase Shifting Transformer (TCPST) are the examples of shunt series controllers.

D. COMBINED SERIES-SERIES CONTROLLERS

This could be a combination of separate series controllers, which are controlled in a coordinated manner, in a multi-line transmission system or it could be a unified controller, in which series controller provides independent series reactive compensation for each line but also transfer real power among the line via the power link.

V. THYRISTOR CONTROLLED SERIES COMPENSATOR

It is obvious that power transfer between areas can be affected by adjusting the net series impedance. One such conventional and established method of increasing transmission line capability is to install a series capacitor, which reduces the net series impedance, thus allowing additional power to be transferred. Although this method is well known, slow switching times is the limitation of its use.

Thyristor controllers, on the other hand, are able to rapidly and continuously control the line compensation over a continuous range with resulting flexibility. Controller used for series compensation is the Thyristor Controlled Series Compensator (TCSC).

TCSC controllers use thyristor-controlled reactor (TCR) in parallel with capacitor segments of series capacitor bank (Figure 1). The combination of TCR and capacitor allow the capacitive reactance to be smoothly controlled over a wide range and switched upon command to a condition where the bi-directional thyristor pairs conduct continuously and insert an inductive reactance into the line.

TCSC is an effective and economical means of solving problems of transient stability, dynamic stability, steady state stability and voltage stability in long transmission lines. TCSC, the first generation of FACTS, can control the line impedance through the introduction of a thyristor controlled capacitor in series with the transmission line.

A TCSC is a series controlled capacitive reactance that can provide continuous control of power on the ac line over a wide range. The functioning of TCSC can be comprehended by analyzing the behavior of a variable inductor connected in series with a fixed capacitor, as shown in Figure 1.

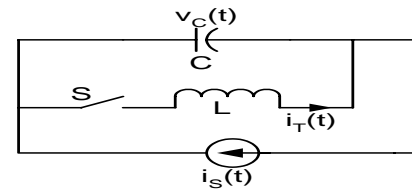

Figure 1. A variable inductor connected in shunt with a fixed capacitor

The steady state thyristor current i_T can be given by:

$$i_T(t) = \frac{k^2}{k^2 - 2} I_m \left(\cos \omega t - \frac{\cos \beta}{\cos k\beta} \cos \omega_r t \right);$$

$$-\beta \leq \omega t \leq \beta$$

$$\text{where, } k = \frac{\omega_r}{\omega} = \sqrt{\frac{X_c}{X_p}}$$

The expression for the capacitor voltage is given by:

$$v_C(t) = \frac{I_m X_c}{k^2 - 1} \left(-\sin \omega t + k \frac{\cos \beta}{\cos k\beta} \sin \omega_r t \right);$$

$$-\beta \leq \omega t \leq \beta$$

The fundamental component, V_{CF} , is obtained as:

$$V_{CF} = 4 / \pi \int_0^{\pi/2} v_c(t) \sin(\omega t) d(\omega t)$$

The equivalent TCSC reactance is given by:

$$X_{TCSC} = \frac{V_{CF}}{I_m} = X_C \frac{X_C^2}{(X_C - X_p)} \frac{2\beta + \sin 2\beta}{\pi} + \frac{4X_C^2}{(X_C - X_p)(k^2 - 1)} \frac{\cos^2 \beta (k \tan \beta - \tan \beta)}{\pi}$$

where V_{CF} = Fundamental component of the capacitor voltage.
 X_C = Nominal reactance of the fixed capacitor only.
 X_p = Inductive reactance of inductor connected in parallel with fixed capacitor.
 β = Angle of advance

VI. TCSC MODELING USING SIMULINK

The complete system has been represented in terms of SIMULINK blocks in a single integral model. SIMULINK is a software tool associated with MATLAB, used for modeling, simulating and analyzing dynamical systems. Single Machine Infinite Bus (SMIB) system with all the required components is modeled and is described. Simulink model of SMIB system with TCSC has been shown in Figure 2.

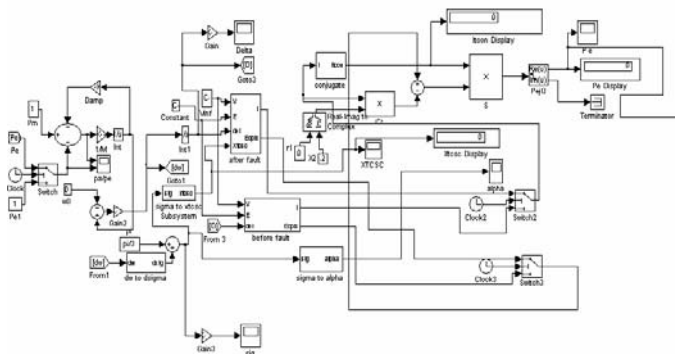

Figure 2. Model of SMIB system using TCSC

VII. SIMULATION RESULTS

This is useful for transient stability study as the power system configuration differ before fault and after fault. The SIMULINK model of SMIB with TCSC controller is analyzed for different conditions of damping constant. Figure 3 shows the rotor angle variation for SMIB with TCSC controller for a damping constant k value 10.

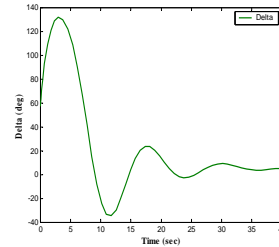

Figure 3 .Rotor angle variation with time for k = 10

Figure 3 shows that the rotor angle (delta) with its initial value at t = 0, increases to its maximum peak and oscillates to attain its steady state within 35-40 sec. At this point the system attains stability. The variation of rotor angle for k = 30 is given in Figure 4 and shows that the time to attain stability is decreased to 15 sec. The effect of varying the damping constant on the power system stability and the value of firing angle (alpha) is shown in Table 1. At t = 0, initially the rotor angle value is very high and at this point the TCSC controller injects the voltage into the line. The analysis shows that if compensation is provided through TCSC controller then the system attains stability at a faster rate.

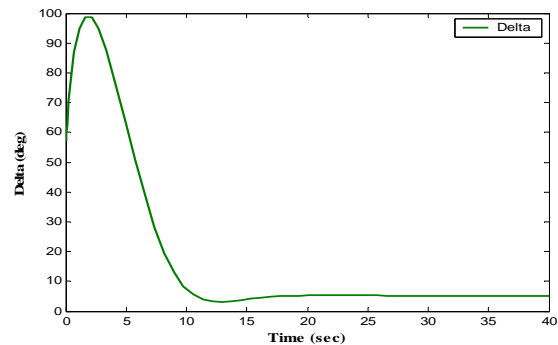

Figure 4. Rotor angle variation with time for k = 30

Now the behaviour of the system is again analyzed by increasing the value of TCSC capacitor. Figure 5. shows the variation of rotor angle when the value of the capacitor of the TCSC (X_c) is varied. When X_c is 0.01, the stability is achieved in 35 – 40sec. Figure 6 shows the variation for $X_c = 3$ which clearly shows that system finally loses its stability.

Table 1. Effect on the stability of Power System with Damping Constant (k)

Damping Constant, k	Time To Attain Stability (sec)	Final Alpha value (deg)
10	35-40	150
20	17	150
25	16	150
30	15	150

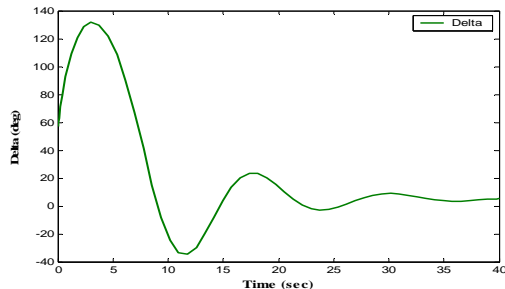

Figure 5. Rotor angle variation with time for $X_c = 0.01$

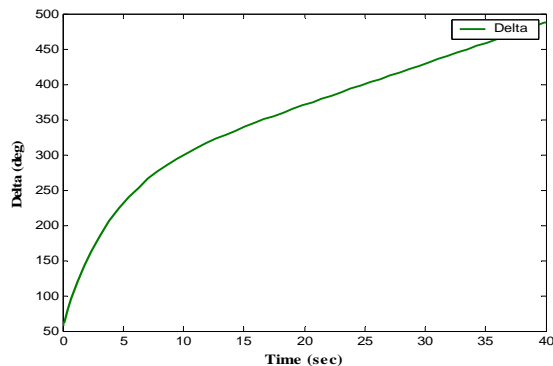

Figure 6. Rotor angle variation with time for $X_c = 3$

CONCLUSION

The analysis shows that the state of the system indicating whether the system is stable or unstable depends upon the reactance of the TCSC controller whose value changes with the change in conduction angle of thyristor in TCSC controller which in turn is governed by the rotor angle.

If the value of damping constant (k) is increased keeping the controller gain, it is observed that the time taken for the system to get into a stable state reduces significantly.

The analysis also shows that if the value of reactance of the fixed capacitor of the TCSC is decreased, the time taken for the suppression of the first highest swing in rotor angle is also increased.

REFERENCES

1. Chatterji.S, Rao.C.S and Nagsarkar T.K., Applications of FACTS controllers for improving Power System Stability, XII National Convention of Electrical Engineers – Power System Management to overcome power shortage, Institution of Engineers (INDIA) Punjab, Haryana and Chandigarh State Center Chandigarh, 23-24 Nov.
2. Chatterji.S, Rao.C.S and Nagsarkar T.K., Admittance characteristics of Thyristor controlled dynamic brake, 9th National Power Systems Conference, IIT Kanpur, 19-21 Dec. 1996.

3. Chatterji.S, Rao.C.S and Nagsarkar T.K., Fuzzy logic based half wave Thyristor controlled dynamic brake, 5th International Conference on Power Electronics and Drive Systems (PEDS-2003) organized by IEEE in Singapore, 17-20 Nov. 2003.
4. N.G.Hingorani and L.Gyugyi, Understanding FACTS Concepts and Technology of Flexible AC Transmission Systems, IEEE Press, New York, 2000
5. R.M.Mathur and R.K.Varma, Thyristor based FACTS Controllers for Electrical Transmission Systems, IEEE Press, Piscataway 2002.
6. A. Edris, “FACTS Technology Development: An Update”, IEEE Power Engineering Review, March 2000.
7. John.J.Paserba, “How FACTS Controllers Benefit AC Transmission Systems”, IEEE Power Engineering Review 2003.
8. B.T.Ooi, “Assessment and Control of the Impact of FACTS Devices on Power System Performance”, IEEE Transactions on Power Systems, Vol. 11, No. 4, Nov. 1996.
9. J.Chen, T.T.Lie, “Enhancement of Power System Damping Using VSC based Series Connected FACTS Controllers”, IEE Proceedings, Generation Transmission Distribution, Vol. 150. No. 3, May-2003.
10. Brian.K.Johnson, “How FACTS Controllers Function In an AC Transmission System”, IEEE Power Engineering Review 2003